

Datasheet

Ball segment valve

Si-101 EN

Edition: 2012-07

Type KVT/KVX

Wafer design

Type KVTF/KVXF

Flanged design

Nominal pressure

PN 50

Nominal size

DN 25/2 - 65

Material

Stainless steel

High nickel alloy (HiNi)

- **Control- and shut-off valve**
- **High capacity**
- **Ball segment and shaft made in one piece, gives a torque transmission free of backlash**
- **Excellent tightness irrespective of differential pressure**

The SOMAS ball segment valve type KVT with a centrally mounted shaft, and KVX with an eccentrically mounted shaft are of wafer design. Type KVTF is a flanged version with centrally mounted shaft while KVXF is a flanged and eccentric design.

The valves in this data sheet are of top entry design. Short face to face dimension, low weight and small space requirement make the installation of these valves very easy. One-piece ball segment and shaft design gives backlash-free operation and accurate control. The shaft is guided in the valve body and stuffing box sleeve. The spring loaded seat is available in PTFE, PTFE 53 and HiCo.

The valves can be used for control, as well as for shut-off applications on practically every type of media within a wide temperature range. Choose KVT/KVTF for liquids, media containing impurities etc. For dry and clean media choose KVX/KVXF. In the KVX/KVXF valve the ball segment is eccentrically mounted and rotates out from the seat when the valve is opened. This reduces the wear on seat and segment.

Low noise (LN) trim is available as an option. The designation "LN" indicates that the ball segment is equipped with a network of bars that are used to split up the pressure drop across the valve. This results in less pressure recovery, thereby reducing the noise and potential damage due to cavitation. In addition the "LN" trim can tolerate media containing a small amount of fibers or particles.

Ball segment with V-groove is available for use at high fibre concentrations. The V-groove design prevents de-watering at small opening angles.

SOMAS valves are delivered ready for installation and operation. The valve assemblies are delivered factory tested as complete units with actuators, positioners and accessories.

Option



- **KVM-ball segment with V-groove for high fibre concentrations**



- **LN (Low Noise) Ball segment with low noise trim for high ΔP**





Tightness class

The tightness class is related to the chosen material in the seat ring.

PTFE seat	Code A	EN 60534-4 VI (ASME B16-104 Class VI)
PTFE 53 seat ¹	Code B	EN 60534-4 VI (ASME B16-104 Class VI)
HiCo seat	Code T	EN 60534-4 IV alt. V (ASME B16-104 Class IV alt. V)

¹ 50% PTFE + 50% 1.4435 (316L) powder (percentage by weight)

Flow characteristics

100% Flow

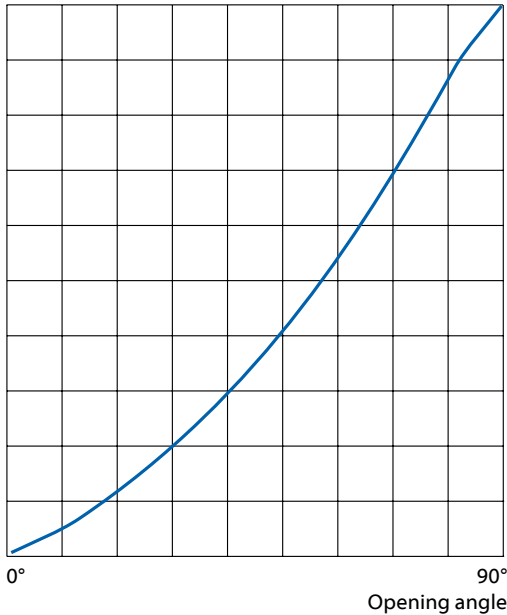

Liquid pressure recovery factor FL

Factor	Opening angle								
	10°	20°	30°	40°	50°	60°	70°	80°	90°
FL	0.85	0.82	0.80	0.77	0.74	0.71	0.67	0.64	0.60

Capacity factor Kv and Resistance factor ξ for ball segment valve type KVT/KVTF

DN	Opening angle										
	10°	20°	30°	40°	50°	60°	70°	75	80°	90°	ξ 90°
25/2	0.003	0.013	0.031	0.053	0.085	0.12	0.16	0.18	—	—	—
25/3	0.003	0.014	0.035	0.067	0.12	0.18	0.26	0.29	—	—	—
25/5	0.014	0.055	0.13	0.23	0.39	0.56	0.72	0.8	—	—	—
25/7	0.05	0.24	0.44	0.6	0.8	1.05	1.3	1.6	—	—	—
25/10	0.2	0.75	1.6	2.2	2.8	3.25	4.05	—	4.25	—	—
25/15	0.21	0.9	1.8	2.8	3.8	5.7	8.1	—	9.9	—	—
25/20	0.21	0.95	2	4.3	6.8	9.5	13.9	—	20	—	—
25	1.7	4.3	7.5	11.3	15.4	20.4	25.7	—	32.8	38	0.43
40/32	1	3.3	6.9	12.9	19	25	35	—	48	—	—
40	4.3	11	19	29	39	53	66	—	84	96	0.44
50	6.8	17	30	45	61	82	103	—	131	150	0.44
65	9.8	25	43	65	87	113	139	—	171	191	0.78

Capacity factor Kv and Resistance factor ξ for ball segment valve type KVX/KVXF

DN	Opening angle										
	10°	20°	30°	40°	50°	60°	70°	75	80°	90°	ξ 90°
25	1,1	3,3	6,1	9,7	13,6	18	23	—	31	35	0,51
40/32	1	3,1	5,9	11,5	17,2	22,5	32,5	—	47	—	—
40	2,7	8,4	15	25	35	46	60	—	80	91	0,49
50	4	13	25	39	54	72	94	—	124	140	0,51
65	6,4	19	35	55	77	99	126	—	162	180	0,88

Relation between Kv and Cv: $K_v = 0.86 \times C_v$

Pressure and temperature rating

According to the material in the seat.

Seat Code	Max. working pressure ¹ (bar at° C)				
	150°	170°	200°	350°	>350°
A	40	32	—	—	Note 1
B	40	32	15	—	Note 1
T	40	32	25	15	Note 1

10 bar = 1 MPa

Note 1: Check with SOMAS

¹ **NB!** Do not exceed working pressure for the valve.

Factor FLP

	Opening angle								
	10°	20°	30°	40°	50°	60°	70°	80°	90°
FLP1	0.85	0.82	0.78	0.75	0.70	0.66	0.60	0.55	0.50
FLP2	0.85	0.82	0.78	0.73	0.68	0.62	0.56	0.50	0.45
FLP3	0.85	0.82	0.78	0.73	0.67	0.61	0.54	0.49	0.43

FLP1 = One dimension bigger pipe size

FLP2 = Two dimensions bigger pipe size

FLP3 = Three dimensions bigger pipe size

Pipe geometry factor Fp

Valve DN	Pipe DN	Opening angle									
		10°	20°	30°	40°	50°	60°	70°	80°	90°	
25	32					0.98	0.96	0.93	0.90	0.85	0.81
	40	1.0	0.99	0.98	0.95	0.91	0.85	0.79	0.71	0.66	
	50				0.92	0.87	0.80	0.73	0.64	0.59	
40	50				0.98	0.97	0.94	0.91	0.87	0.83	
	65	1.0	0.99	0.98	0.95	0.91	0.85	0.79	0.71	0.66	
	80				0.92	0.87	0.80	0.73	0.64	0.59	
50	65				0.98	0.96	0.93	0.89	0.86	0.84	
	80	1.0	0.99	0.98	0.95	0.91	0.85	0.79	0.71	0.66	
	100				0.92	0.87	0.80	0.73	0.64	0.59	
65	80				0.99	0.98	0.97	0.96	0.93	0.91	
	100	1.0	0.99	0.98	0.95	0.91	0.85	0.79	0.73	0.64	
	125				0.92	0.87	0.80	0.73	0.64	0.59	



Wafer design

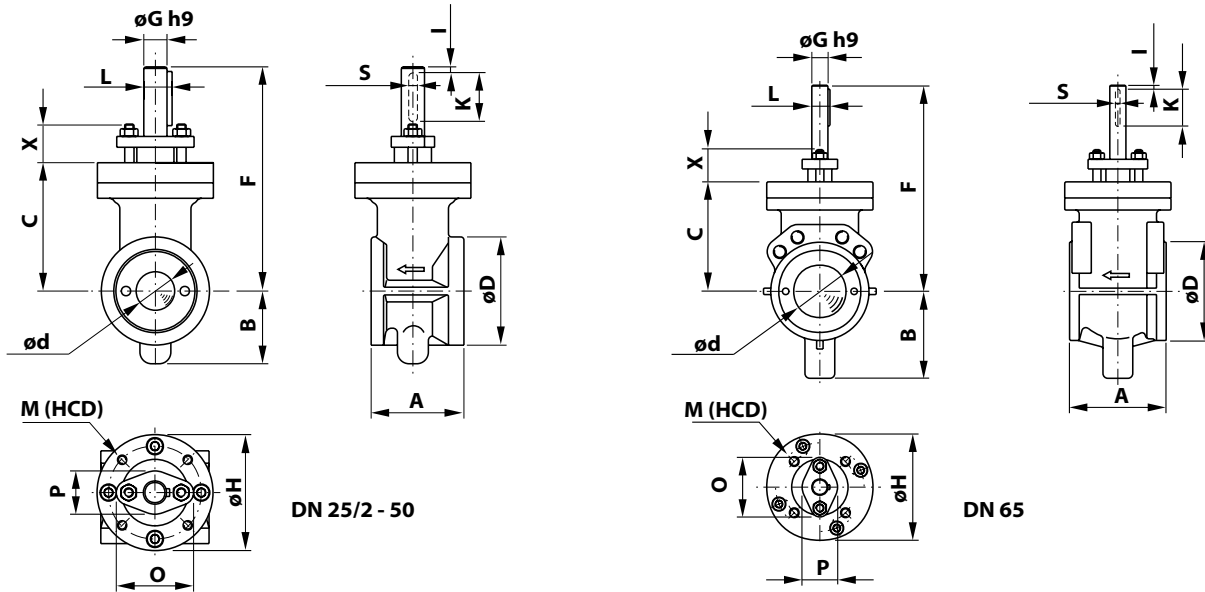

Ball segment valve type KVT/KVX

DN	A	B	C	øD	ød	F	øG	øH	I	K	L	M	(HCD)	O	P	S	X	Weight	DN
25/2	60	47	83	70	2	145	15	75	3	35	17	M6	60	50	28	5	25	2.5	25/2
25/3	60	47	83	70	3	145	15	75	3	35	17	M6	60	50	28	5	25	2.5	25/3
25/5	60	47	83	70	5	145	15	75	3	35	17	M6	60	50	28	5	25	2.5	25/5
25/7	60	47	83	70	7	145	15	75	3	35	17	M6	60	50	28	5	25	2.5	25/7
25/10	60	47	83	70	10	145	15	75	3	35	17	M6	60	50	28	5	25	2.5	25/10
25/15	60	47	83	70	15	145	15	75	3	35	17	M6	60	50	28	5	25	2.5	25/15
25/20	60	47	83	70	20	145	15	75	3	35	17	M6	60	50	28	5	25	2.5	25/20
25	60	47	83	70	25	145	15	75	3	35	17	M6	60	50	28	5	25	2.5	25
40/32	85	64	106	93	32	170	15	95	3	35	17	M8	80	50	28	5	25	5	40/32
40	85	64	106	93	40	170	15	95	3	35	17	M8	80	50	28	5	25	5	40
50	95	72	116	108	50	180	15	105	5	35	17	M8	80	50	28	5	25	7	50
65	120	108	136	122	60	255	20	132	5	45	22.5	M12	90	74	44	6	40	14	65

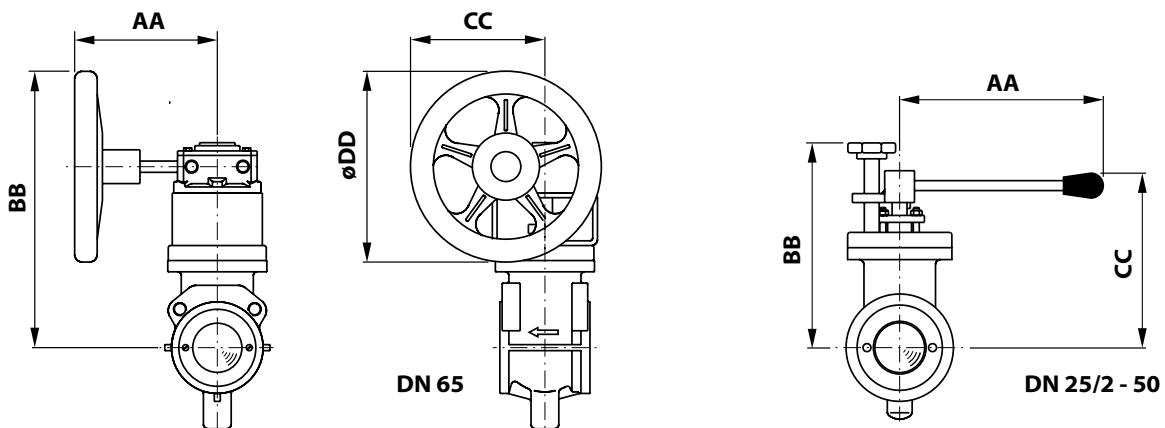

Ball segment valve type KVT/KVX with hand gear

DN	Type	AA	BB	CC	øDD	Weight
25/2 - 25	M5/F05	155	200	105	125	6
40/32 - 40	M5/F05	155	225	105	125	9
50	M5/F05	155	240	105	125	11
65	M10/F07	190	370	180	255	22

Ball segment valve type KVT/KVX with hand lever

DN	Type	AA	BB	CC	Weight
25/2 - 25	HK115	195	175	145	3
40/32 - 40	HK125	195	200	170	6
50	HK125	195	210	180	8
65	HSR	350	305	245	16



Wafer design

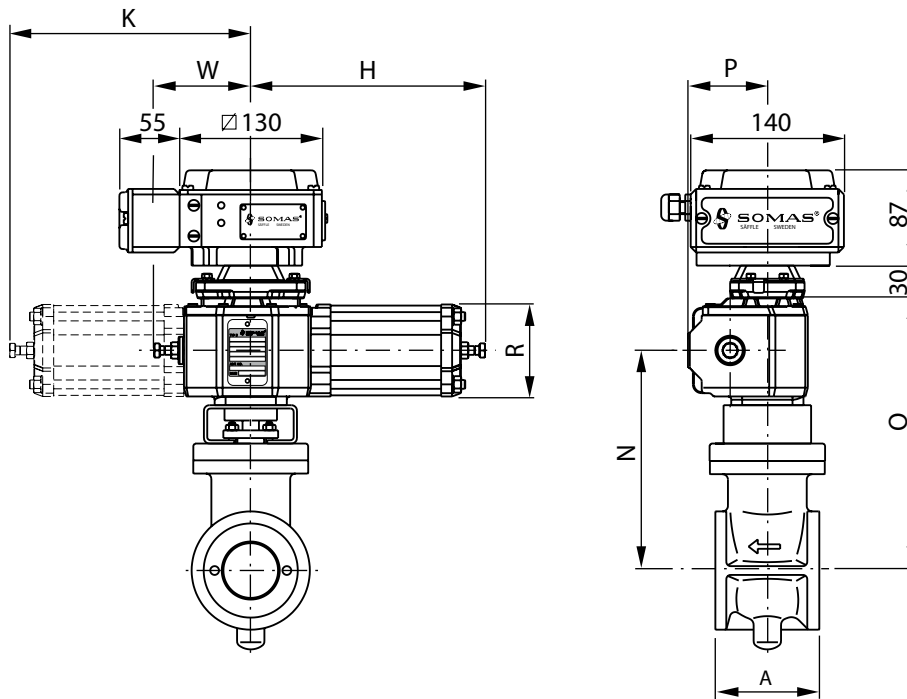

Ball segment valve type KVT/KVX with actuator type A-DA

DN	Type	H	K	N	O	P	R	W	Weight
25/2 - 25	A11	215	–	170	215	73	84	90	7
40/32 - 40	A11	215	–	190	240	73	84	90	9
50	A13	250	–	200	250	83	106	90	13
65	A21	255	–	280	345	94	106	140	24
65	A22	255	260	280	345	94	106	–	25

For units with the positioner type SP405, add 2 kg
 For units with the positioner type SPE405, add 3 kg

Ball segment valve type KVT/KVX with actuator type A-SC/SO

DN	Type	H	K	N	O	P	R	W	Weight
25/2 - 25	A13-X	325	–	170	215	83	106	90	11
40/32 - 40	A13-X	325	–	190	240	83	106	90	13
50	A13-X	325	–	201	250	83	106	90	15
50	A23-X	415	–	240	305	117	152	140	24
65	A23-X	415	–	280	345	117	152	140	32

X = SC - Spring to close

X = SO - Spring to open

For units with the positioner type SP405, add 2 kg

For units with the positioner type SPE405, add 3 kg



Flanged design

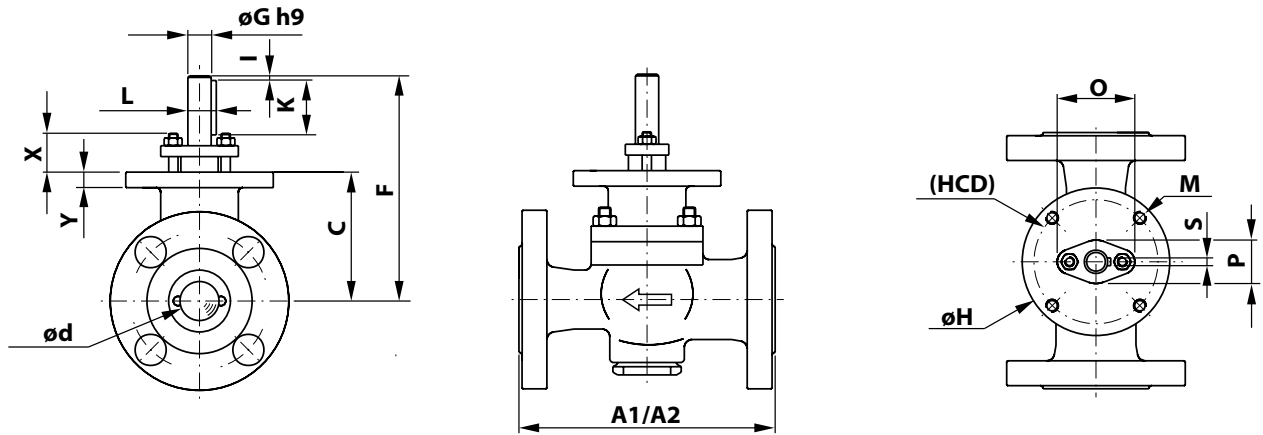

Ball segment valve type KVTF/KVXF

DN	A1	A2	C	ϕd	F	ϕG	ϕH	I	K	L	M	(HCD)	O	P	S	X	Weight	DN
25/2	160	165	83	2	145	15	95	3	35	17	M8	80	50	28	5	25	6.5	25/2
25/3	160	165	83	3	145	15	95	3	35	17	M8	80	50	28	5	25	6.5	25/3
25/5	160	165	83	5	145	15	95	3	35	17	M8	80	50	28	5	25	6.5	25/5
25/7	160	165	83	7	145	15	95	3	35	17	M8	80	50	28	5	25	6.5	25/7
25/10	160	165	83	10	145	15	95	3	35	17	M8	80	50	28	5	25	6.5	25/10
25/15	160	165	83	15	145	15	95	3	35	17	M8	80	50	28	5	25	6.5	25/15
25/20	160	165	83	20	145	15	95	3	35	17	M8	80	50	28	5	25	6.5	25/20
25	160	165	83	25	145	15	95	3	35	17	M8	80	50	28	5	25	6.5	25
40/32	200	190	106	32	170	15	95	3	35	17	M8	80	50	28	5	25	11	40/32
40	200	190	106	40	170	15	95	3	35	17	M8	80	50	28	5	25	11	40
50	230	216	116	50	180	15	95	5	35	17	M8	80	50	28	5	25	14	50

A1 = Face to face dimension according to EN 558 series 1 (PN 25, PN 40)

A2 = Face to face dimension according to EN 558 series 4 (PN 20, PN 50, Class 150, Class 300)

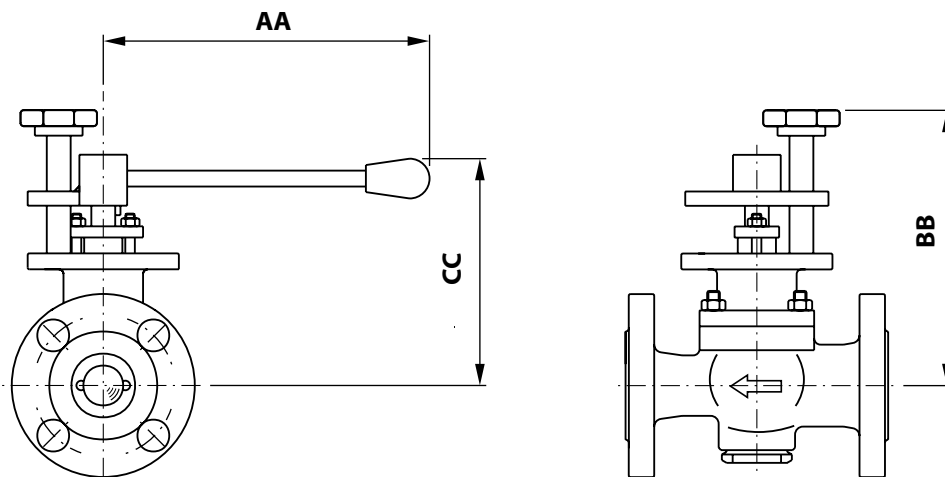

Ball segment valve type KVTF/KVXF with hand lever

DN	Type	AA	BB	CC	Weight
25/2 - 25	HK125	195	180	150	7
40/32 - 40	HK125	195	200	170	12
50	HK125	195	210	180	16



Flanged design

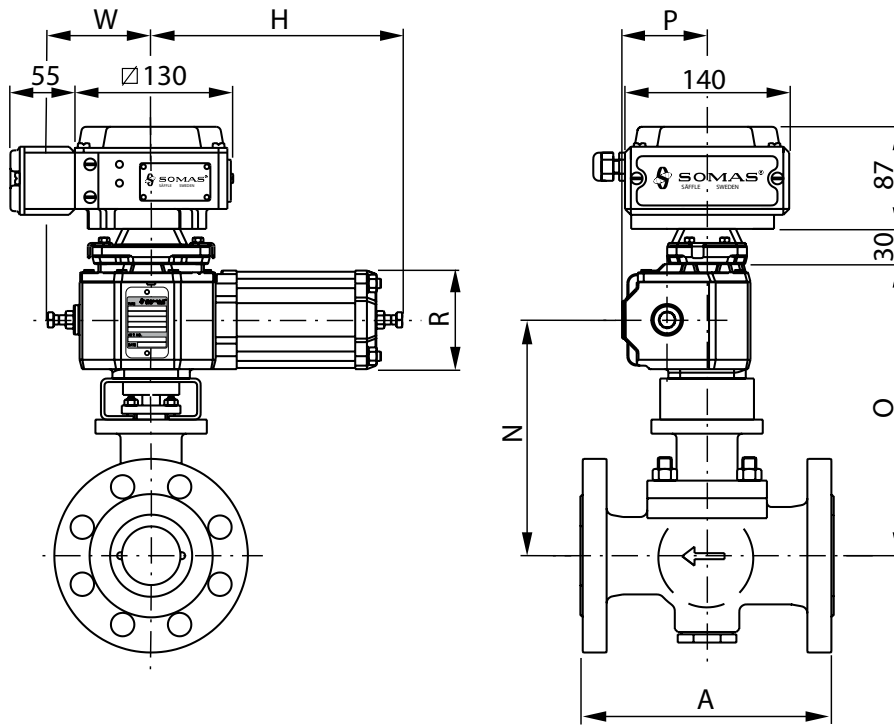

Ball segment valve type KVTF/KVXF with actuator type A-DA

DN	Type	H	N	O	P	R	W	Weight
25/2 - 25	A11	215	185	215	73	84	90	11
40/32 - 40	A11	215	190	240	73	84	90	15
50	A13	250	200	250	83	106	90	20

For units with the positioner type SP405, add 2 kg
 For units with the positioner type SPE405, add 3 kg

Ball segment valve type KVTF/KVXF with actuator type A-SC/SO

DN	Type	H	N	O	P	R	W	Weight
25/2 - 25	A13-X	325	170	215	83	106	90	15
40/32 - 40	A13-X	325	190	240	83	106	90	19
50	A13-X	325	200	250	83	106	90	22
50	A23-X	415	240	305	117	152	140	30

X = SC – Spring to close
 X = SO – Spring to open
 For units with the positioner type SP405, add 2 kg
 For units with the positioner type SPE405, add 3 kg



Flange standard

SOMAS ball segment valves type KVT and KVX with nominal size DN 25/2 – 65 are flangeless and should be clamped between flanges.

The valves type KVTF and KVXF with nominal size DN 25/2 – 50 are flanged and can be drilled according to PN 10 - 50 and Class 150/300.

When ordering, please always state the pressure rating of the counter flanges. See the valve specification system on page 8, code 11.

Torque

Valve DN	Shaft dia. (mm)	Necessary closing torque	
		Min. (Nm)	Max. (Nm)
25/2 - 25	15	25	80
40/32 - 40	15	45	80
50	15	55	80
65	20	120	200

Selection table

Valve DN	Pneumatic actuators						Manual override	
	Double acting		Spring return				Hand lever	Gear unit
	5.5 bar	4 bar	Spring to close		Spring to open			
			5.5 bar	4 bar	5.5 bar	4 bar		
25/2 - 25	A11-DA	A11-DA	A13-SC	A13-SCL	A13-SO	A13-SOL	HK115 ¹ /HK125 ²	M5/F05
40/32 - 40	A11-DA	A11-DA	A13-SC	A13-SCL	A13-SO	A13-SOL	HK125	M5/F05
50	A13-DA	A13-DA	A13-SC	A23-SC	A13-SO	A23-SOL	HK125	M5/F05
65	A21-DA	A22-DA	A23-SC	A23-SC	A23-SO	A23-SOL	HSR	M10/F07

¹ KVT/KVX DN 25/2 - 25

² KVTF/KVXF DN 25/2 - 25

Option

Within the process industry and the energy sector there are a number of applications where process data in combination with standard control valves will end up with problems such as high noise level and erosion. These problems are mostly related to cavitation and high flow velocities inside the valve.

Note! By using a standard ball segment valve and add a noise reduction trim many of the above mentioned problems can be solved.

See data sheet Si-108 for more theoretical information.

For controlling suspensions with high fibre concentrations it can be advantageous to use valves with a V-groove to reduce the risk of de-watering at small opening angles.

Further technical information

Technical data for the materials used in the SOMAS valves, flange standard, steam data, etc. can be found in section 6 of the SOMAS catalogue.

Actuators and accessories

The valves can be fitted with SOMAS manual, on/off or control actuators in accordance with the selection table. The valves will then be delivered as tested units ready for installation.

Check sections 4 and 5 of the SOMAS catalogue, where positioners, limit switches and solenoid valves are also presented.

We can also fit other types of actuators and accessories in accordance with your specification.

Capacity factors and remaining factors for valves with LN-trim and valves with V-groove are available in the valve sizing program SOMSIZE.

Valve sizing

Use SOMAS valve sizing program SOMSIZE to find the correct valve size. All sizing factors are included in the program.



Ordering

State desired valve according to the valve specification system below as well as type of actuator, positioner and accessories.

Valve specification system

KVT - A 6 - A K A - B 1 1 - DN... - PN...

1 Type of valve

Wafer design

KVT (centrically mounted segment)
KVX (eccentrically mounted segment)
KVT LN¹ (centr. mounted segment, Low Noise)
KVX LN¹ (eccentr. mounted segment, Low Noise)
KVM¹ (ball segment with V-groove)

Flanged design

KVTF (centrically mounted segment)
KVXF (eccentrically mounted segment)
KVTF LN¹ (cent. mounted segment, Low Noise)
KVXF LN¹ (eccentr. mounted segment, Low Noise)
KVMF¹ (ball segment with V-groove)

2 Valve body design

A = Wafer design
L = Flanged design

3 Nominal pressure

6 = PN 50

4 Material – valve body

A = CF8M
B = CF8M, hard chromed
C = 1.4409
T = HiNi² (High Nickel alloy)

5 Material – ball segment

J = 1.4460³
K = 1.4460³, hard chromed
L = 1.4460³, HiCo coated
V = HiNi² (High Nickel alloy)

6 Material – seat

A = PTFE⁵ (10% carbon)
B = PTFE 53^{4,5}
T = HiCo⁶ (High Cobalt alloy)
W = Without seat²
hard chromed cover plate

7 Material – shaft

A = 1.4460³
B = 1.4460³, hard chromed
G = 1.4460³, hard chromed
U = HiNi² (High Nickel alloy)

8 Bearings – valve body/shaft

1 = Without bearing
4 = Rulon

9 Stuffing box

1 = Graphite
2 = PTFE

10 Valve size, DN

11 Drilling, counter flanges, PN/Class

¹ Only DN 50

² Not for KVTF/KVXF

³ 2324-12 for DN 65

⁴ 50% PTFE + 50% 1.4435 (316L) powder (percentage by weight)

⁵ (DN 25/7 - DN 65)

⁶ (DN 25/2 - 65)

SOMAS reserves the right to make improvements without prior notice.



SOMAS[®]
www.somas.se

Box 107
SE-661 23 SÄFFLE
SWEDEN

Phone: +46 533 167 00
Fax: +46 533 141 36
E-mail: sales@somas.se